

RS-232 – I²C Adapter/Monitor

Revision 3.8, October 2006

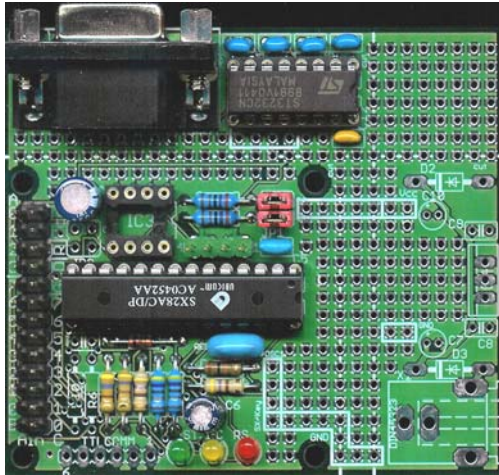

This adapter provides an easy-to-use interface between devices on an I²C bus and an RS-232 serial communications port of a PC, or any other device with a serial port.

The adapter's command set contains various options to interact with the I²C bus. The so-called "*high-level*" commands perform the necessary tasks for complete communications with I²C devices transparent to the application controlling the RS-232 side. This means setting the start condition, sending the address and the read/*write bit, sending or reading data bytes reading or setting the acknowledge bit, and finally generating the stop condition is completely handled by the adapter.

As the adapter returns results with a leading "O" in case of successful operations, or an "E" in case of errors, data read from an I²C device must be buffered in the adapter's memory before transmitting it via RS-232. This buffer has a size of 16 bytes, i.e. the maximum number of bytes that can be read from an I²C device with a high-level command is limited to 16.

The adapter command set also contains so-called "*low-level*" commands to interact with the I²C bus "more directly". Such commands require a bit more activities on the RS-232 side. They allow for any number of data bytes transferred to or from an I²C device. They are also useful to communicate with I²C devices that expect sequences other than the ones handled by the "high-level" commands.

Besides its major task to translate between RS-232 and I²C, the adapter also accepts commands via RS-232 to handle 13 parallel input or output lines. Eight lines also clock internal 16-bit counters which can be read, or reset by designated commands.

For debugging, or test purposes, a "Monitor Mode" can be activated which turns the adapter into an I²C "spy". In this mode, activities on the monitored I²C bus are transmitted via the RS-232 interface.

As an option, a serial EEPROM, pin-compatible to 24LC01, 24LC02, etc. devices can be installed on-board.

The adapter makes use of an SX28 micro controller. Therefore, by modifying the controller software, the adapter can easily be adapted to special customer requirements.

Since version 3.2, the adapter is built on a 4-layer PCB with one inner layer connected to V_{dd} (positive supply), and the other layer connected to V_{ss} (ground). This technology makes sure that international EMC regulations are met and it also increases the noise immunity of the adapter.

Important Notice: *When possible, do not drill additional holes into the PCB in order to avoid possible shortages between the two inner layers. If this can't be avoided, please double-check that there is no short between the positive and negative supply signals. Should this be the case, carefully widen the drilled hole until the short is gone.*

Electrical Specifications

Supply voltage:	3.3 to 5 V DC stabilized, or 8...12 V DC, non-stabilized, approx. 100 mA (with an additional voltage regulator installed), or 8...36 V DC (with an additional DC/DC converter installed).
Maximum voltage on all pins:	7 V
Parallel inputs:	TTL level with Schmitt-Trigger characteristics, controller-internal pull-up resistors (approx. 10 kOhm) against the positive supply voltage.
Parallel outputs:	TTL-level, maximum current, outputs can sink or source: 30 mA. <i>Note: When switching inductive loads like relays, suppressor diodes are required</i>
Serial interface:	+/- 12 V, according to the RS-232 specifications. 38400 Baud, 8N1, no handshake (with the Monitor mode active, data will be sent at a baud rate of 112.5 kBaud – see "Monitor Mode" for more details).

Interface to the PC

Communication with the PC is performed via the TxD and RxD signals of an RX-232 serial port at 38400 Baud, 8 bits, no parity, one stop bit. There are no handshake lines required. In monitor mode, a Baud rate of 112500 is used – see "Monitor Mode".

The adapter's 9-pin SUB-D jack must be connected to a COM port of the PC, using a "straight through" serial cable. A "Null Modem" cable will not work.

I²C Interface

For communication via the I²C bus according to the specifications of Philips, the signals

Serial Data (SDA)
Serial Clock (SCL)

are available. Both signal lines are open collector. On the adapter, both lines are connected to the positive supply voltage via pull-up resistors. When pull-up resistors already exist elsewhere on the bus, the adapter's pull-up resistors can be de-activated by removing two on-board jumpers.

Parallel Inputs/Outputs

The controller has three I/O ports where one (port A) has four I/O pins that are used for the serial communication (RxD and TxD with the PC, and SDA/SCL for the I²C bus), and two ports (port B and port C) each with 8 I/O pins. The upper three port C pins are used to control the three status LEDs. The remaining lower five port C pins, and the eight port B pins are free for general I/O. The adapter's CONFIGURE I/O command (U) allows to define each of these I/O pins individually to act as input or output. The port pins can be accessed via the extension header pins marked "C4...0" and "B7...0").

When the adapter is powered-up, reset, or after a BREAK, all I/O pins are configured as inputs by default.

Two commands, IN (N), and OUT (O) allow reading or writing all I/O pins. Two more commands, READ PIN (n), and WRITE PIN (o) allow to read or write pins individually.

The OUT command expects two parameter bytes, where the first byte controls the port C pins, and the second byte controls the port B pins. The upper three bits of the first parameter are always ignored, as these upper three port C pins are always configured as outputs to control the status LEDs. The remaining bits of the two OUT parameters only control port pins when they are configured as outputs by a CONFIGURE I/O command before – pins that are configured as inputs are ignored.

The IN command returns two bytes, where the first byte returns the status of the lower five port C pins with the upper three bits always set to 0, and the second byte returns the status of the eight port B pins. For port pins that are defined as outputs, the returned bits are set to the current output states, for pins defined as inputs, the returned bits are set to the current input state.

The READ PIN command expects one parameter, the pin number, and it returns the status of the specified pin. Pin numbers go from 12 to 8 for the port C pins 4 to 0, and from 7 to 0 for the port B pins 7 to 0.

The WRITE PIN commands expects two parameters with the first parameter specifying the pin number like for the READ PIN command, where the second parameters specifies the new output setting. A value of 0 sets the pin to low, any other value sets it to high level.

For port pins defined as outputs, the read commands return the current output state. For pins defined as inputs, the read commands return the levels currently applied to the pins.

Pins defined as inputs are not affected by the output commands.

All port pins that are defined as inputs are connected to the supply voltage via internal pull-up resistors (approx. 10 kΩ) and have Schmitt-Trigger characteristics.

Each of the eight port B pins also control eight internal 16-bit counters. On each positive transition (low → high) on a port B pin, the associated counter is incremented by one. Commands are available to read or clear one or all of these counters. The inputs are sampled at a rate of about 1 MHz, and don't have any de-bouncing provisions. If necessary, external components must be provided to avoid that "spikes" cause false counter results.

When port B pins are configured as outputs, the counters will advance when the associated port pin is changed from low to high.

General Information About I²C Communications

Via the I²C bus one or more so-called “Masters” communicate with one or more so-called “Slaves”. Here, the I²C adapter is supposed to be the only master in the system, and all I²C components connected to the bus must act as slaves, i.e. they are supposed to react on commands that are sent from the PC via the adapter.

When a master wants to establish a communication, it first generates a start condition on the bus (SDA 1→0 while SCL = 1), and then sends an address/mode byte having the following format:

aaaaaaam

where “aaaaaaa” is the 7-bit address of the selected slave, and “m” indicates a read or write operation (m = 0: write, m = 1: read). After having received this byte, the selected slave pulls low the SDA line for acknowledge, and the master checks if the slave has acknowledged. If this is not the case, there is an error (slave not ready, not existing, having a different address, or some other fault).

When the master has initiated a write operation, it sends one or more data bytes following the address/mode byte, where each of these bytes must be acknowledged by the slave. At the end of a transmission, the master generates the stop condition on the bus (SDA 0→1 while SCL = 1).

When the master has initiated a read operation, it receives one or more bytes from the slave, and sends an acknowledge for each of these bytes except for the last one. By not sending an acknowledge for the last byte, the master indicates the slave not to send more bytes. Finally, the master generates the stop condition on the bus (SDA 0→1 while SCL = 1).

Further options of the I²C protocol, like clock-stretching, 10-bit addresses, multi-master mode, or handling of bus arbitrations are not required here, and are not supported.

Since firmware version 3.7, special versions of the Adapter’s TX and RX commands are available that allow to send a so-called “Start Byte”, as defined in the recent I²C specification (see RX1S, RXnS, TX1S, and TXnS).

IMPORTANT NOTE: *The commands that communicate with I²C components expect a 7-bit address, i.e. the most significant bit must always be 0. This address value is automatically shifted one bit position to the left, and the lowest bit will be set on read, or cleared on write commands. For example, when a device expects an address/mode byte of 0xa0 for write and 0xa1 for read, the address value sent to the adapter must be 0x50, i.e. the upper seven bits (1010000) of the address/mode byte.*

Purpose of the RS-232 – I²C Adapter

Besides converting the electrical levels, i.e. from ±12 V to 0/+5 V for the TxD and RxD RS-232 signals, the major task of the adapter is to make the communication with components on the I²C bus as transparent as possible to the application running on the PC. This application can communicate with the adapter by using simple command sequences, that could be generated by a Visual BASIC application, for example.

The application sends a command character (plus some more characters, depending on the command) to the adapter. Commands that address the adapter itself are immediately acknowledged, where I²C commands issue the adapter to start a communication on the I²C bus. When this communication is completed, the adapter first returns a status character (“O”, or “E”) indicating if the operation was successful or not.

In case the operation was successful, the adapter returns one or more result bytes. In case of an error, the adapter returns just the error code “E”.

Idle Mode

When the adapter is powered up, has received a BREAK command, after a time-out, or a reset, it enters the "Idle" mode, i.e. the I²C bus is held in idle condition (SDA and SCL both at high level), and no communication will be performed via the I²C bus. All commands received via RS-232 are answered with "S" (except the INIT command), and the status LED blinks.

To terminate the idle mode, an INIT command must be sent. This command sets some adapter parameters. After an INIT command has been received, the adapter accepts other commands via the RS-232 interface, and the status LED lights steadily.

It is also possible to turn the adapter from "Idle" directly into the "Monitor" mode (see the MONITOR command).

Time-Out

The INIT command allows the definition of a time-out value. When the specified time-out interval elapses before the adapter has received a new valid command via RS-232, it will enter the "Idle" mode, i.e. no more I²C communications are performed.

The PC application on the other hand, should also perform a time-out check. When it does not receive acknowledges from the adapter within a certain time interval, it should send a BREAK, followed by a new INIT command in order to reset the adapter.

CLEAR COUNTER

Sequence:	c + CHR(<n>) → → O E
Allowed values for <n>:	0..7
Function:	Clears the counter that is assigned to the port B pin specified with <n> (0..7).
Returns:	O = Reset successful. E = Value <n> out of range.

This command clears the 16-bit counter that is associated to the input specified with <n>.

CONFIGURE I/O PINS

Sequence:	U + CHR(CfgC) + CHR(CfgB)→ → O
Function:	Configures the controller's port pins as inputs or outputs where the CfgC parameter specifies the port C pin settings, and the CfgB parameter the port B pin settings. When a parameter bit is 0, the associated port pin is configured as output, else it is configured as input. The upper three bits of the CfgC parameter are always ignored, and cleared to define the upper three port C pins as outputs for the three status LEDs. Pins configured as outputs will automatically cleared (set to low level) by this command. At power-on, or after a BREAK, or reset, all pins are configured as inputs by default.
Returns:	O = Success

COUNTER READ

Sequence:	C + CHR(<n>) → → O + CHR(<h>) + CHR(l) E
Allowed values for <n>:	0..7
Function:	Reads the contents of the counter that is assigned to the port B pin specified by <n> (0..7).
Returns:	O = Read successful, <h> is the high counter byte, and <l> is the low counter byte. E = Value <n> out of range.

This command reads the current contents of the 16-bit counter associated to Port B pin <n>.

COUNTER READ ALL

Sequence: A →
 → O + CHR(<h₇>) + CHR(<l₇>) + CHR(<h₆>) + CHR(<l₆>) +
 CHR(<h₅>) + CHR(<l₅>) + CHR(<h₄>) + CHR(<l₄>) +
 CHR(<h₃>) + CHR(<l₃>) + CHR(<h₂>) + CHR(<l₂>) +
 CHR(<h₁>) + CHR(<l₁>) + CHR(<h₀>) + CHR(<l₀>)

Function: Reads the contents of all counters assigned to the port B pins.

Returns: O = Success, the subsequent sixteen bytes contain the current counter values, starting with the counter for port B pin 7 down to pin 0; each value in high-low byte order.

INIT

Sequence: I + <c> + CHR(<to>) + CR →
 → O + <hhl> | E

<c> = I²C bit rate kBit/s
 <to> = Timeout period
 <hhl> = Adapter Version-Id (3 ASCII characters)
 hh = Major version
 l = Minor version

e.g.: 036 = Version 3.6

Allowed values for <c>:

0	=	25 kBits/s
1	=	50 kBits/s
2	=	100 kBits/s
3	=	200 kBits/s
4	=	400 kBits/s
5	=	3 kBits/s

Allowed values for <to>: 0...255 For <to> = 0, no timeout checking is performed, otherwise, <to> defines the time interval in steps of 100 ms, i.e. time intervals between 100 ms, and 25.5 s may be selected.

Function: Initializes the adapter, and terminates the idle mode, i.e. communication via the I²C bus is enabled.

When the adapter does not receive new commands via RS-232 within the period defined with the <to> parameter, the adapter will reactivate the idle mode again, so another INIT command is necessary to restart it again.

Returns: O + <hhl> = Successful initialization, <hhl> contains the adapter version number, e.g. "037" means version 3.7
 E = Error – an illegal number of parameters, or bad parameters were sent.

INPUT

Sequence: N →
→ O + CHR(<valC>) + CHR(<valB>)

Function: Reads the port C and B lines, and returns the result pattern in <valC> (0...31) and <valB> (0...255).

For port C lines 7 to 5, a result of 0 is always returned as these port pins are used to control the adapter's status LEDs.

Please note that open input pins return a 1 in the result byte as these lines are pulled to high level via the internal pull-up resistors.

Returns: O + CHR(<valC>) + CHR(<valB>)

MONITOR

Sequence: M →
→ CHR<byte> + +|- + { CHR<byte> + +|- + ... }

Function: This command activates the adapter's monitor mode. In this mode, all outputs are set to high impedance. The green status LED blinks, and the yellow I²C activity LED is turned on.

The adapter then monitors the I²C bus. Whenever it detects an activity on the bus, it returns the byte sent over the bus, followed by "+" when it has detected an acknowledge, or a "-", when no acknowledge was detected.

In case a stop condition has been detected on the bus, the adapter returns a CR/LF sequence instead of a byte followed by "+" or "-". This allows the PC application to filter this special character sequence in order to insert a new line in the monitor protocol, for example.

In order to terminate the monitor mode, a BREAK command must be issued.

To enter the monitor mode, it is not necessary to initialize the adapter before issuing the MONITOR command.

Note: With the monitor mode active, the adapter will send data via the COM port at a rate of 112500 Baud to allow for the highest possible transfer rate. The PC application must re-configure the PC's COM port to operate at 112500 Baud after having sent the "M" command. When the Monitor mode is terminated, the application must re-configure the Baud rate to 38400 Baud again before sending a new INIT command to the adapter.

The adapter internally makes use of a 32 byte FIFO buffer for the bytes and acknowledge states. This makes it possible to monitor bus systems using a data rate of up to 100 kBits/s, provided that there is no continuous communication on the bus. When the FIFO buffer overflows before characters could be sent to the PC, bus activities will get lost.

OUTPUT

Sequence: O + CHR(<valC>) + CHR(<valB>) →
→ O

Function: Sets the five output port C bits according to the pattern in <valC>, and the eight port B bits according to the pattern in <valB>.

Note that only bits are affected that are configured as output bits before with the CONFIGURE I/O PINS (U).

Returns: O

PING

Sequence: P →
→ O

Function: Used to check if the adapter is available, and operational. When this is the case, an "O" is returned for acknowledge, otherwise, no answer is sent (the PC application should implement a timeout to handle this situation).

Returns: O

READ PIN

Sequence: n + CHR(<pin-#>) →
→ O + CHR(<pin status>) | E

Function: This command reads the status of an I/O pin. It expects one parameter specifying the pin number. Valid bit numbers are 12...8 for the port C pins 4...0, and 7...0 for the port B pins 7...0. Values above 12 are not accepted, and an error code will be returned.

For port pins configured as inputs, the current level applied to the pin will be returned. For pins configured as outputs, the current pin output level will be returned.

Returns: O = Read successful, pin status follows (0 = low, 1 = high)
E = Bad bit number parameter passed.

READ BYTE WITH ACK

Sequence: E →
→ CHR(<byte>)

Function: This "low-level" I²C-command reads a byte (<byte>, 0...255) from the I²C device which was addressed for read last, and then sets the acknowledge condition.

In order to receive meaningful data with this command, it is necessary to first address a bus device for read (see SEND READ ADDRESS). Without addressing a valid I²C device first, this command will always return CHR(255), or 0xFF.

You may then issue any number of subsequent READ BYTE WITH ACK commands, e.g. to read out sequential data from an EEPROM. Often, the sequential read must be terminated with a read followed by no acknowledge (see READ BYTE WITHOUT ACK).

Returns: <byte>

READ BYTE WITHOUT ACK

Sequence: e →
→ CHR(<byte>)

Function: This “low-level” I²C command reads a byte (<byte>, 0...255) from the I²C device which was addressed for read last, and then clears the acknowledge condition.

In order to receive meaningful data with this command, it is necessary to first address a bus device for read (see SEND READ ADDRESS). Without addressing a valid I²C device first, this command will always return CHR(255), or 0xFF.

Usually, I²C devices, like EEPROMS can be sequentially read by reading single bytes followed by an acknowledge (use READ BYTE WITH ACK). In order to terminate the sequential read, the last read must not be followed by an acknowledge, i.e. use this READ BYTE WITH NACK command for this purpose.

Returns: <byte>

RX1

Sequence: R + CHR(<addr>) →
→ O + CHR(<val>) | E

Function: This “high-level” command issues a start condition, sends the 7-bit address <addr> (0...127) plus the R/W-bit set, then reads a byte (<val>, 0...255) from the I²C device, sets the acknowledge bit (for no Ack), and finally issues a stop condition.

Returns: O = Read successful, byte read follows
E = Error (no acknowledge from the device, or <addr> > 127)

Note: This is a special version of the RXN command. No length parameter is required here, i.e. the communication is slightly faster here.

RX1S

Sequence: G + CHR(<addr>) →
→ O + CHR(<val>) | E

Function: This “high-level” command issues a start condition, sends a start byte (0x01), ignores the acknowledge bit, issues another start condition, and then sends the 7-bit address <addr> (0...127) plus the R/W-bit set, reads a byte (<val>, 0...255) from the I²C device, sets the acknowledge bit (for no Ack), and finally issues a stop condition.

Returns: O = Read successful, byte read follows
E = Error (no acknowledge from the device, or <addr> > 127)

Note: This is a special version of the RXnS command. No length parameter is required here, i.e. the communication is slightly faster here.

RXn

Sequence: r + CHR(<addr>) + CHR(<n>) →
→ O + CHR(<val1>) {+ CHR(<val2>) + ...} | E

Function: This “high-level” command issues a start condition, sends the 7-bit address <addr> (0...127) plus the R/W-bit set, then reads <n> bytes (<valx>, 0...255) from the I²C device with the acknowledge bits cleared, and finally issues a stop condition.

Returns: O = Read successful, bytes read follow.
E = Error (no acknowledge from the device, <n> > 16, or <addr> > 127).

RXnS

Sequence: g + CHR(<addr>) + CHR(<n>) →
→ O + CHR(<val1>) {+ CHR(<val2>) + ...} | E

Function: This “high-level” command issues a start condition, sends a start byte (0x01), ignores the acknowledge bit, issues another start condition, then sends the 7-bit address <addr> (0...127) plus the R/W-bit set, reads <n-1> bytes (<val1...n-1>, 0...255) from the I²C device with the acknowledge bits cleared, the last byte (<valn>) with the acknowledge bit set, and finally issues a stop condition.

Returns: O = Read successful, bytes read follow.
E = Error (no acknowledge from the device, <n> > 16, or <addr> > 127).

SEND BYTE

Sequence: B + CHR(<Byte>) →
→ O | E

Function: This “low-level” command sends a byte via the I²C bus. Before issuing this command, it is necessary to send an address (see SEND ADDRESS) to select the I²C device which shall receive the byte. You

may issue any number of subsequent SEND BYTE commands, e.g. to write a block of data into an EEPROM.

Returns: O = The bus device has acknowledged.
E = The bus device has not acknowledged.

SEND READ ADDRESS WITH START

Sequence: D + CHR(<addr>) →
→ O | E

Function: This “low-level” command issues the start condition on the bus, and then sends an address for read. Note that <addr> must be a value between 0 and 127. This value is automatically shifted left one bit position, and the least significant bit (the r/w bit) is set.

Returns: O = The bus device has acknowledged.
E = The bus device has not acknowledged.

SEND READ ADDRESS WITHOUT START

Sequence: d + CHR(<addr>) →
→ O | E

Function: This “low-level” command sends an address for read without previously setting the start condition on the bus. Note that <addr> must be a value between 0 and 127. This value is automatically shifted left one bit position, and the least significant bit (the r/w bit) is set.

Some I²C devices first expect a start condition, followed by a write address, a configuration byte, and then another address for reads. You can combine the SEND WRITE ADDRESS WITH START, SEND BYTE, and this SEND READ ADDRESS WITHOUT START commands for that purpose. Usually one or more READ BYTE commands will follow next, in order to read data from the I²C device.

Returns: O = The bus device has acknowledged.
E = The bus device has not acknowledged.

SEND WRITE ADDRESS WITH START

Sequence: W + CHR(<addr>) →
→ O | E

Function: This “low-level” command issues the start condition on the bus, and then sends the specified address for write. Note that <addr> must be a value between 0 and 127. This value is automatically shifted left one bit position, and the least significant bit (the r/w bit) is cleared.

Returns: O = The bus device has acknowledged.
E = The bus device has not acknowledged.

SEND WRITE ADDRESS WITHOUT START

Sequence: w + CHR(<addr>) →
→ O | E

Function: This “low-level” command sends the specified address for write without setting the start condition prior to sending the address. Note that <addr> must be a value between 0 and 127. This value is automatically shifted left one bit position, and the least significant bit (the r/w bit) is cleared.

Returns: O = The bus device has acknowledged.
E = The bus device has not acknowledged.

STOP

Sequence: S →
→ O

Function: Sets the stop condition on the I²C bus. This is a “low-level” utility function that might be called after an error was detected in order to reset the slave components connected to the bus.

Returns: O

TX1

Sequence: T + CHR(<addr>) + CHR(<val>) →
→ O | E

Function: This “high-level” command sets the start condition, sends the 7-bit address <addr> (0...127) with the r/w-bit cleared, then sends the byte <val> (0...255), reads the acknowledge, and finally generates a stop condition.

Returns: O = Success
E = Error (no acknowledge from the I²C device, or <addr> > 127).

Note: This is a special version of the TXN command. No length parameter is required here, so the communication is slightly faster here.

TX1S

Sequence: F + CHR(<addr>) + CHR(<val>) →
→ O | E

Function: This “high-level” command issues a start condition, sends a start byte (0x01), ignores the acknowledge bit, issues another start condition, sends the 7-bit address <addr> (0...127) followed by a cleared r/w-bit, then sends the byte <val> (0...255), reads the acknowledge, and finally generates a stop condition.

Returns: O = Success
E = Error (no acknowledge from the I²C device, or <addr> > 127).

Note: This is a special version of the TXnS command. No length parameter is required here, so the communication is slightly faster here.

TXn

Sequence: t + CHR(<addr>) + CHR(<n>) + CHR(<val1>) {+ CHR(<val2>) + ...} →
→ O | E

Function: This "high-level" command sets the start condition, sends the 7-bit address <addr> (0...127) with the r/w-bit cleared, then sends <n> bytes <valx> (0...255), reads the acknowledge bits, and finally generates the stop condition.

Returns: O = Success
E = Error (no acknowledge from the I²C device, or <addr> > 127).

TXnS

Sequence: f + CHR(<addr>) + CHR(<n>) + CHR(<val1>) {+ CHR(<val2>) + ...} →
→ O | E

Function: This "high-level" command issues a start condition, sends a start byte (0x01), ignores the acknowledge bit, issues another start condition, sends the 7-bit address <addr> (0...127) followed by a cleared r/w-bit, then sends <n> bytes <valx> (0...255), reads the acknowledge bits, and finally generates the stop condition.

Returns: O = Success
E = Error (no acknowledge from the I²C device, or <addr> > 127).

WRITE PIN

Sequence: o + CHR(<pin-#>) + CHR(<setting>) →
→ O | E

Function: This command sets the status of an output pin. It expects two parameters, where the first parameter defines the pin number. Valid pin numbers are 12...8 for the port C pins 4...0, and 7...0 for the port B pins 7...0. Values above 12 are not accepted, and an error code will be returned.

The second parameter specifies the pin setting. When this parameter is 0, the port pin will be cleared (low), any other value will set the port pin (high).

When this command is applied to port pins configured as inputs, no error will be reported but the command does not affect the port pins.

Returns: O = Command successful
E = Bad bit number parameter passed.

Bad Commands

Sequence: <?> →
 → ?

Function: When commands are sent to the adapter that are not specified, they will be answered with “?”.

Adapter Command Summary

Id	Function
none	BREAK – Force an adapter reset
a	CLEAR ALL COUNTERS – Clears all counter
A	COUNTER READ ALL – Reads all counters
B	SEND BYTE – Send a byte via the bus, and return acknowledge
c	CLEAR COUNTER – Clear a counter
C	COUNTER READ – Read a counter
d	SEND ADDRESS FOR READ WITHOUT START – Sends an address for read without setting the start condition
D	SEND ADDRESS FOR READ WITH START – Sets the start condition, and sends an address for read
e	READ BYTE WITHOUT ACK – Reads a byte, and does not acknowledge
E	READ BYTE WITH ACK – Reads a byte, and sets acknowledge
f	TXnS – Send a start byte, and n data bytes via I ² C
F	TX1S – Send a start byte, and one data byte via I ² C
g	RXnS – Send a start byte, and receive n bytes via I ² C
G	RX1S – Send a start byte, and receive one byte via I ² C
I	INIT – Initialize the adapter
M	MONITOR – Enter the monitor mode
n	READ PIN – Read an adapter input port pin
N	INPUT – Read the adapter input port
o	WRITE PIN – Set an I/O port pin
O	OUTPUT – Set the adapter output port
P	PING – Check if adapter is ready
r	RXN – Receive one or more bytes via I ² C
R	RX1 – Receive a byte via I ² C
S	STOP – Set the stop condition on the I ² C bus
t	TXN – Send one or more bytes via I ² C
T	TX1 – Send a byte via I ² C
U	CONFIGURE I/O PINS – Configures the adapter's I/O pins
w	SEND WRITE ADDRESS WITHOUT START – Sends an address for write without setting the start condition
W	SEND WRITE ADDRESS WITH START – Sets the start condition, and sends an address for write

Note: Grayed = “low-level” function.

Adapter Pin Connections

All adapter signals (except serial data) are available on a 28-pin header (2 * 13) with 1/10" spacing. The signals for the serial interface (TxD, RxD, Signal Ground) are connected to the 9-pin SUB-D jack.

There is an additional 4-pin header available (1/10" spacing) connected to the I²C signals SCL, SDA, and to Vdd (positive supply voltage, and Vss (ground).

The right area of the PCB (not shown in the picture below) allows the installation of a voltage regulator, the required filter capacitors, and protection diodes and also a DIN low voltage connector, allowing to supply the adapter with unregulated DC power (8...12 Volt). In case, the voltage regulator is not required, this part of the PCB may be cut off when the footprint size of the PCB is of importance 56 mm width instead of 65 mm).

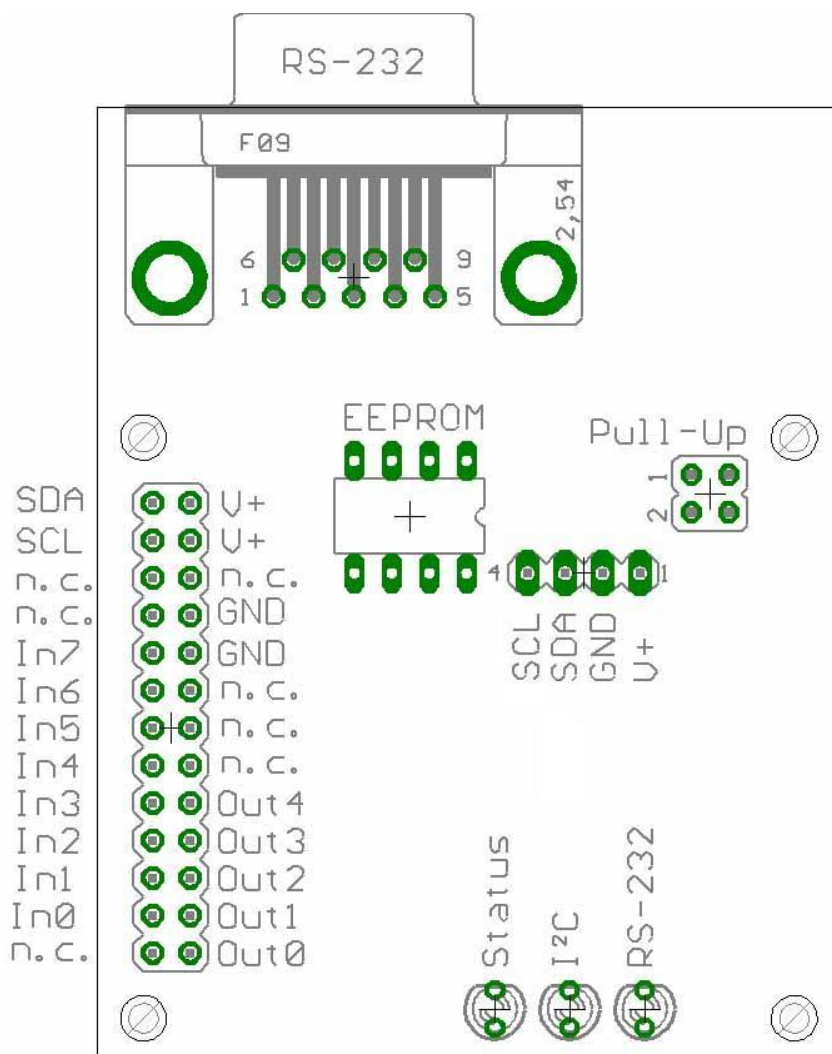

Adapter connections, viewed from the component side.

26-pin Header

The 26-pin header is connected to all I/O lines, and to the I²C bus (SDA/SCL). The pins V+ and GND are used to apply the supply voltage (3.3...5 V DC, stabilized). The pins marked as "n.c." should not be connected because they are connected to other I/O lines of the SX controller that are used internally.

4-Pin Header

This header can be used to alternatively connect the adapter to an I²C bus. It is also possible to feed in the supply voltage here.

Jumper "Pull-Up"

When the two upper, and the two lower pins of this jumper block are connected, the adapter's internal pull-up resistors between the positive supply voltage, and the SDA/SCL bus lines are activated. When the jumpers are removed, the pull-up resistors are de-activated. In this case, it is important that somewhere else on the bus pull-up resistors are active.

SUB-D 9 jack "RS-232"

This jack is used to connect the adapter to the COM port of a PC. There are only three pins connected:

Pin 2: Adapter TxD → PC RxD

Pin 3: Adapter RxD → PC TxD

Pin 5: Signal Ground

LEDs

The green "Status" LED indicates the adapter's status:

blinking	Adapter is not initialized
steadily on:	Adapter is initialized

The yellow "I²C" LED flickers when there are activities on the I²C bus. When the monitor mode is active, this LED is steadily on, and the green Status LED blinks.

The red "RS232" LED flickers on data transfer via the serial RS-232 lines.

Component Location "EEPROM"

At this location, a serial EEPROM, pin-compatible to types like 24LC01, 24LC02, etc. may be installed. The three address select bits A0, A1, and A2 (pins 1, 2, and 3) are all connected to V_{dd}, resulting in a device address of 111 for this EEPROM.

Adapter Schematic

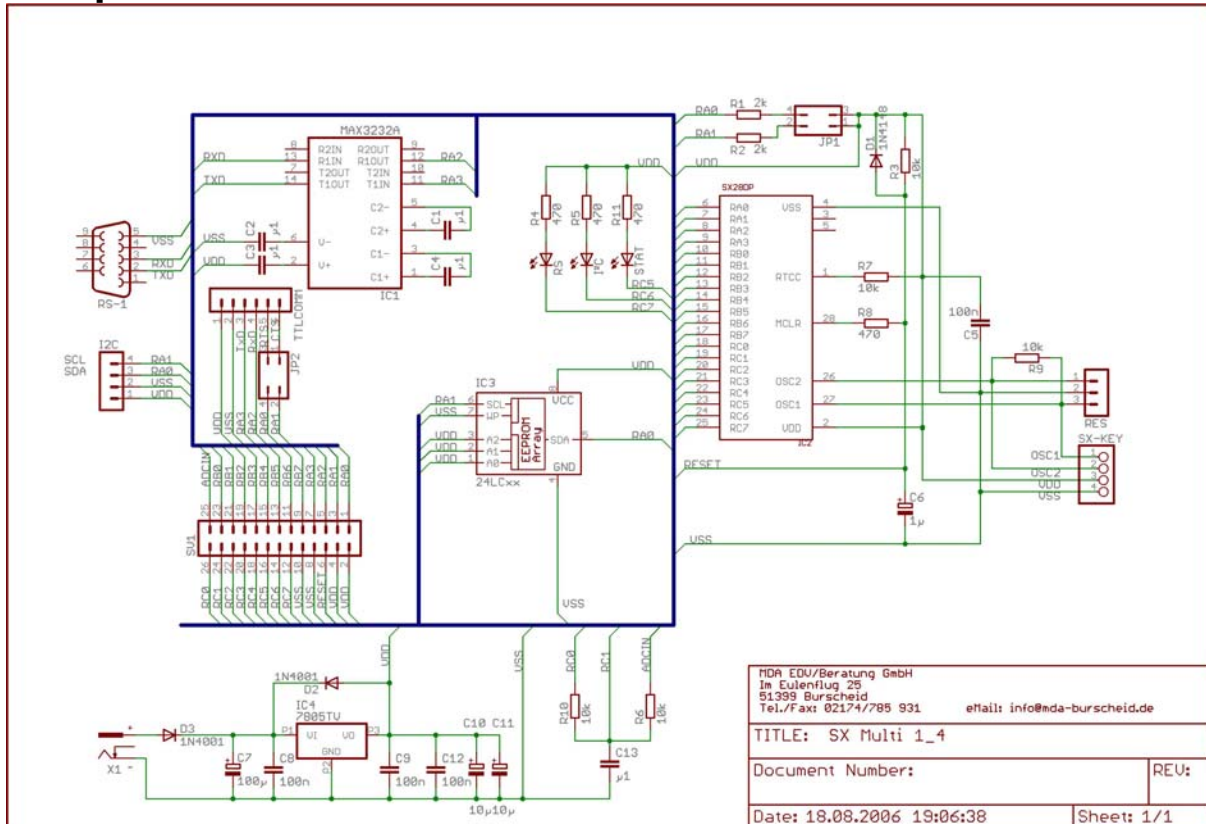

Note: Not all components shown may be installed, depending on the adapter configuration.

Test Program for the Adapter

The adapter is shipped with a CD-ROM that contains a test application allowing to test the adapter with a PC. The program was developed in Microsoft Visual Basic. The source and project files are also distributed on the CD-ROM. You may use them as hints for your own applications.

When the program is launched, the following window will open:

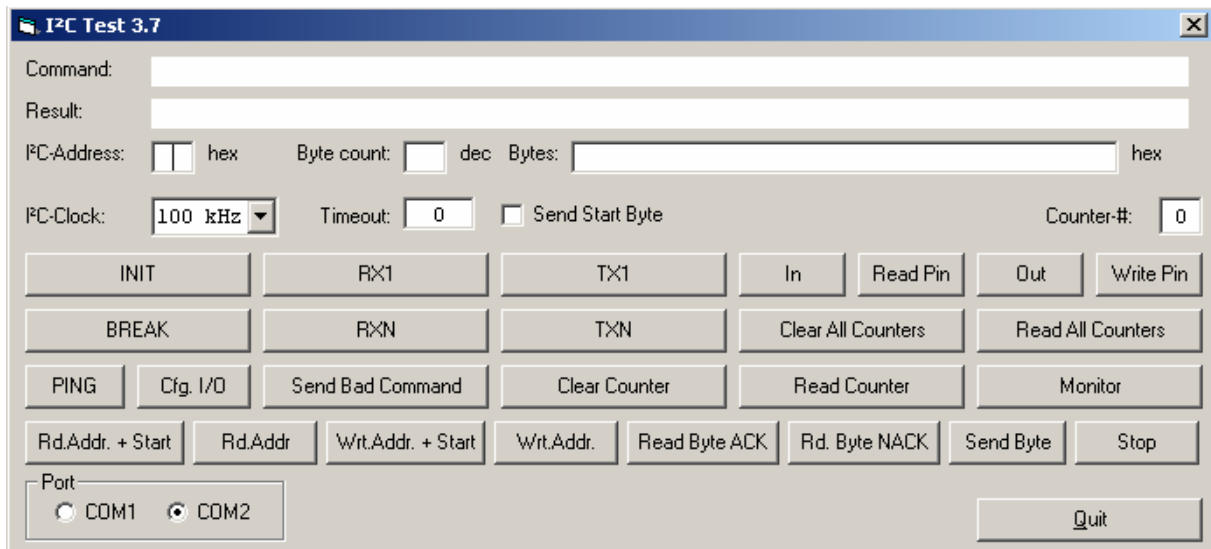

Provided that the adapter has power supply (the green LED is blinking), and that the serial port is connected to one of the PC's COM ports (COM1, or COM2), you may execute the following operations:

Selecting a COM-Port

Click the radio button in the "Port" section to select the COM port that shall be used for communications.

The buttons described next send various commands to the adapter. The line "Command" shows the characters sent (values enclosed by <> are in hexadecimal). The "Result" line displays the answers being returned by the adapter.

INIT

This sends an INIT command. If necessary, you may change the defaults "I2C-Clock", or "Timeout" before sending the INIT. Setting "Timeout" to some other value but 0 means that you will have to send commands repeatedly. Otherwise, the adapter would perform a reset after the timeout has elapsed.

After clicking INIT, the adapter's green LED should light steadily, indicating that the initialization was accepted, and the "Result" line should display "Onnn", where "nnn" is the adapter's version number. This has terminated the adapter's idle mode.

Following the initialization, other commands may be sent to the adapter, but it makes sense to send a PING command first.

PING

This command is used to test if the adapter is ready.

BREAK

This button sends a BREAK command to the adapter. Another INIT command is required to activate the adapter again.

Cfg. I/O

This button sends a CONFIGURE I/O command to the adapter. This command expects two bytes which define the configuration of the I/O port pins. Enter them in the "Bytes" field as two hexadecimal numbers with at least one space to separate the numbers. For example, "0 0" will set all pins as outputs and "1F FF" sets all pins as inputs.

Sending, and Receiving I²C-Data

Before sending, or receiving I²C data, the address of an I²C component connected to the bus must be entered in the "I²C Address" field. Please enter the address in hexadecimal as 7-bit value (i.e. bit 7 is always clear). The adapter will automatically shift the address bits to the left by one bit position, and add the read/write bit as LSB.

When the adapter could successfully communicate with an I²C component, the first character returned is an "O". When an error has occurred, an "E" will be returned instead.

Errors will occur when the adapter does not receive an acknowledge from the addressed device. Reasons may be that a bad address has been specified, or that the I²C bus may be broken, or that the addressed component is defective, or does not exist.

Check Box "Send Start Byte"

With this option checked, when clicking the RX1, RXN, TX1, and TXN buttons, the corresponding RX1S, RXnS, TX1S, or TXnS commands are sent to the adapter, so that an initial Start Byte (0x01 without acknowledge check) is sent via the I²C bus.

RX1

This button sends a read command for a single data byte to the I²C device with the address specified in the address field. On successful communication, the "Result" field will contain the sequence "O <xx>", where <xx> stands for the value read from the device in hexadecimal notation.

RXN

This button sends a read command for one or more bytes to the I²C device with the address specified in the "Address" field. Before clicking this button, enter the number of bytes to be received in the "Byte count" field. In case the device answers, the "Result" field will display "O <xx> <xx>..." where <xx> contain the bytes read from the device in hexadecimal.

TX1

This button sends a write command for one data byte to the I²C device with the address specified in the "Address" field. When the device acknowledges, the "Result" field will display "O", else it will display "E". Before clicking this button, enter a hexadecimal value in the "Bytes" field without any specific characters, e.g. "1d", but not 0x1d, or <1d>. When the "Bytes" field contains more than one hexadecimal value, e.g. "1d 2a ff aa", the leftmost one (1d) will be sent.

TXN

This button sends a write command for one or more data bytes to the I²C device with the address specified in the "Address" field. When the device acknowledges, the "Result" field will display "O", else it will display "E". Before clicking this button, enter the number of bytes to be transmitted in the "Byte count" field, and enter enough hexadecimal values in the "Bytes" field, each separated with at least one space, without any specific characters, e.g. "1d 2a ff aa", but not "0x1d 0x2a", or "<1d> <2a> <ff> <aa>". When this field contains more values than were specified in the "Byte count" field, values will be read and sent from left to right from the "Bytes" field until the specified number of bytes has been sent.

Send Bad Command

This button is used to test the adapter's reaction when it receives an unknown command (it returns "?" for "unknown command").

Parallel Input/Output

The adapter has twelve available input/output pins.

IN

This button issues an INPUT command to read the status of the adapter's parallel inputs. The Result field displays "O cc bb" where "cc" is the hexadecimal value representing the current status of the C port, and "bb" the hexadecimal value representing the current status of the B port.

Read Pin

This button sends a READ PIN command to the adapter. This command expects the pin number as parameter. Enter it in the "Bytes" field before as hex number. Valid numbers are 0...C (bit 0 to 12)

OUT

This button issues an OUTPUT command, setting the output lines of the adapter according to the two hexadecimal values in the "Bytes" field which must be entered before clicking the "OUT" button.

Write Pin

This button issues a WRITE PIN command. It expects two parameters entered as hex numbers in the "Bytes" field, separated by at least one space. The first parameter specifies the bit number (0...C), and the second parameter the new bit setting. A value of 0 will clear the bit – any other value will set it.

Counter Functions

For each pot B pin, the adapter maintains a 16-bit counter. Whenever it detects a rising signal edge on one of the pins, it increments the associated counter. These counters can be read and reset individually, or all together.

The buttons "Clear Counter", "Read Counter", "Clear all Counters" und "Read all Counters" are used for these operations. The number in the "Counter-#" field selects the counter for "Clear Counter" and "Read Counter".

Please note that the counter inputs don't perform any de-bouncing. If necessary, external components are required to perform that task. Also, no specific action is taken when a counter overflows from 0xFFFF to zero.

“Low-Level” I²C Functions

In order to communicate with special I²C devices which don't match the “high-level commands”, like TX1, TXn, RX1, and RXn, the adapter provides these “low-level” functions.

Rd.Addr + Start

This button issues a SEND ADDRESS FOR READ WITH START command, i.e. the start condition will be set first, and then the 7-bit address in the “I²C-Address” field together with the r/w-bit set will be sent.

Rd.Addr

This button issues a SEND ADDRESS FOR READ WITHOUT START command, i.e. the 7-bit address in the “I²C-Address” field together with the r/w-bit set will be sent without setting the start condition prior to sending the address.

Wrt.Addr + Start

This button issues a SEND ADDRESS FOR WRITE WITH START command, i.e. the start condition will be set first, and then the 7-bit address in the “I²C-Address” field together with the r/w-bit cleared will be sent.

Wrt.Addr

This button issues a SEND ADDRESS FOR WRITE WITHOUT START command, i.e. the 7-bit address in the “I²C-Address” field together with the r/w-bit set will be sent without setting the start condition prior to sending the address.

Rd.Byte ACK

This button issues a READ BYTE WITH ACK command, i.e. one byte will be read from the bus, and the acknowledge bit will be set low. Please note that it is necessary to issue any SEND READ ADDRESS command in order to select the desired I²C device for reading before using this function. When you continuously receive “ff” as the result, it is most likely that no I²C device has answered because none was addressed before.

Rd.Byte NACK

This button issues a READ BYTE WITHOUT ACK command, i.e. one byte will be read from the bus, and the acknowledge bit will be left high. Please note that it is necessary to issue any SEND READ ADDRESS command in order to select the desired I²C device for reading before using this function. When you continuously receive “ff” as the result, it is most likely that no I²C device has answered.

I²C devices, like EEPROMs usually allow to sequentially read data, where the sequential read is terminated by sending no acknowledge after the last byte read. This can be accomplished by this function.

Send Byte

This button issues a SEND BYTE command, i.e. the leftmost byte in the “Bytes” field will be sent via the bus. Please note that it is necessary to issue any SEND WRITE ADDRESS command in order to select the desired I²C device for writing before using this function to send a byte. When the I²C device acknowledges the write operation, an “O” will be displayed in the “Result” field, else an “E” will be shown.

Monitor

Clicking this button opens the Monitor window:

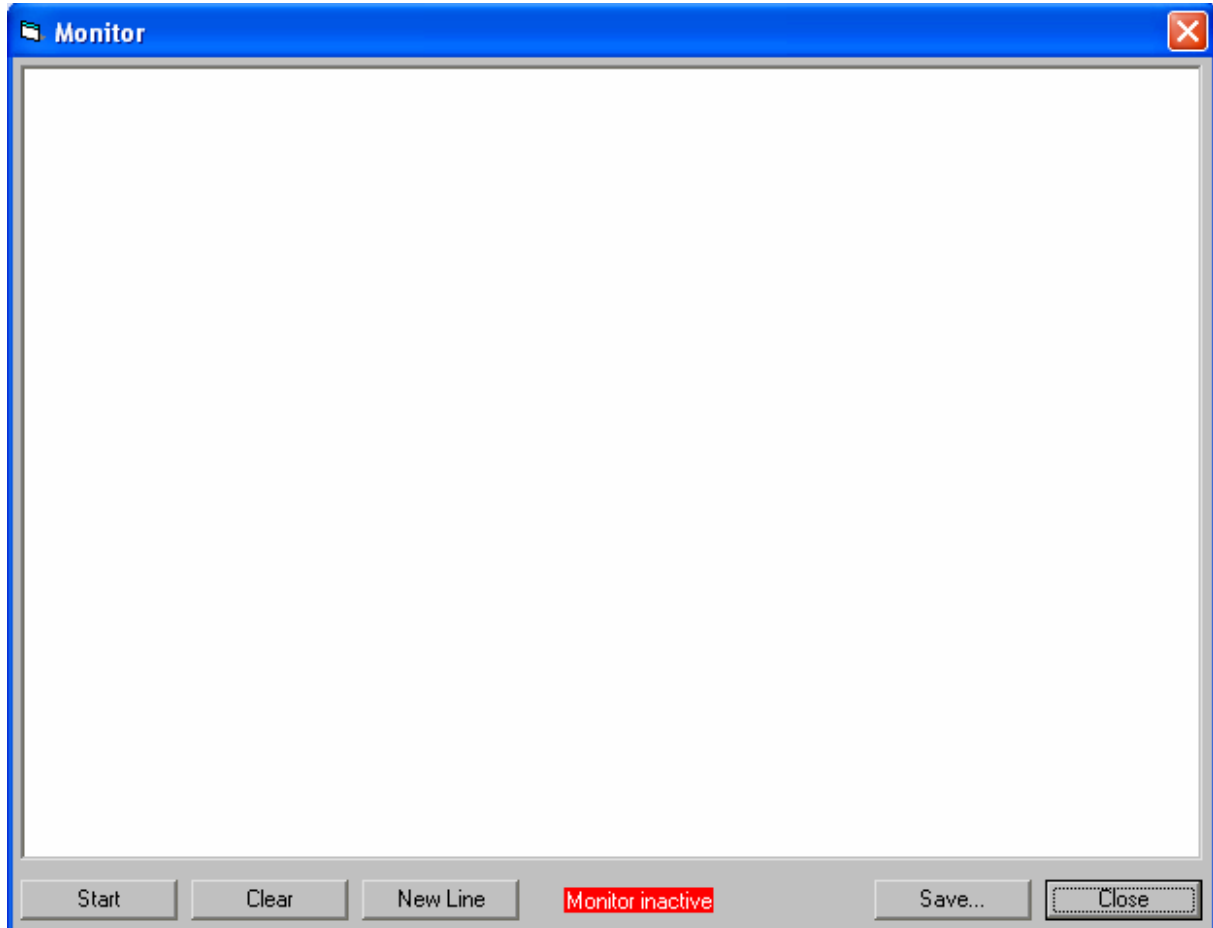

When you click the "Start" button the first time, a MONITOR command will be sent to the adapter which activates its monitor mode. The caption of the "Start" button will change to "Stop" then, and the "Monitor inactive" message changes to "Monitor active". The baud rate will be automatically set to 112500 Baud in order to handle the data received from the adapter.

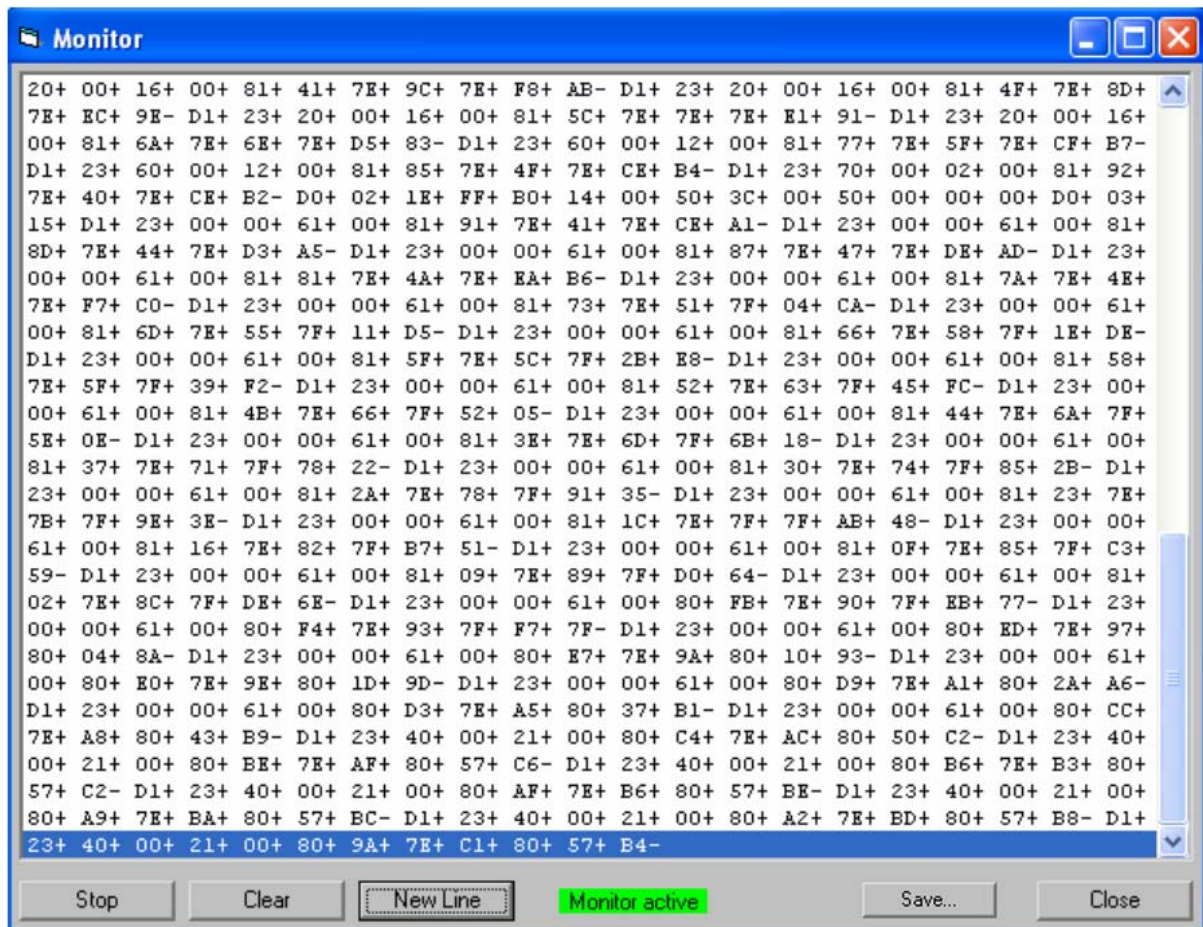

Now, all bytes the adapter “sees” on the I²C bus will be displayed in the list area of the monitor window in a format like this:

```
xx+ xx+ xx- xx-
```

where “xx” stands for the hexadecimal value of the detected byte. The trailing plus indicates that the byte was acknowledged, where a trailing minus indicates that the byte was not acknowledged.

When you click the “Stop” button, the adapter will remain in the monitor mode, and continue receiving characters but they will not be added to the list area until you click the “Start” button again.

You may click the “Clear” button at any time to delete all data displayed in the list area. The “New Line” button inserts a line break at the current position in the list area.

The “New Line” button can be used to insert a line break at the current display position.

The “Save” button opens a file select dialog. Here you may specify the file name used to save the captured data in ASCII text format.

When you click the “Close” button, the Monitor window will be closed, and a BREAK command is sent to the adapter in order to terminate the monitor mode. The COM port will be automatically re-configured to 38400 Baud for “normal” communication with the adapter.



Final Note:

This document describes the current adapter software which is subject to be changed at any time without prior notice.